

Expandet ESI Xtreme Pro Injection Mortar

Expandet ESI Xtreme Pro is the professional all round bonded anchor solution that provides expansion free, safe and fast anchorage of threaded rod, socket anchors with internal thread, rebar etc. in most types of base materials. ESI Xtreme Pro is also suitable for use in wet, flooded holes. ETA and CE-marked in option 1 (cracked concrete) and seismic use. ETA and CE marked for post-installed rebar according to EC2. Use of a professional injection gun (H245) is recommended. Fire Tested R120.



ADVANTAGES

- ESI Xtreme Pro for use in concrete, solid & hollow brick, Light weight concrete & aerated concrete.
- ETA and CE marked use in loadbearing constructions when using steel grade 4.6, 5.8, 8.8, 10.9, A4-50 & A4-70 in concrete.
- Wide range of embedment depth - allows for optimized embedment depth.
- Can be used close to the edge and with a small spacing.
- Applicable in dry/wet and flooded holes.
- Seismic.
- Anchorages can be designed in Expandet Anchor Calculation Programme. For download go to www.expandet.dk



ACCESSORIES

Wide range of accessories.

ESI Xtreme Pro - Maximum working time and minimum curing time

Temperature ¹⁾	Geltime	Curingtime
-10°C → -6°C ²⁾	90 min ²⁾	24 h
-5°C → -1°C	90 min ³⁾	14 h
0°C → +4°C	45 min ³⁾	7 h
+5°C → +9°C	25 min ³⁾	2 h
+10°C → +19°C	15 min ³⁾	80 min
+20°C → +29°C	6 min ³⁾	45 min
+30°C → +34°C	4 min ⁴⁾	25 min
+35°C → +39°C	2 min ⁴⁾	20 min

- ¹⁾ In concrete
²⁾ Cartridge temp. Min: + 5°C Max: + 25°C
³⁾ Cartridge temp. Min: + 15°C
⁴⁾ Cartridge temp.: Must be between +5°C and +25°C (**Only acc. EC2 for rebar**)
⁵⁾ Cartridge Temp.: Must be below +20°C (**Only acc. EC2 for rebar**)
 • In wet concrete the curing time must be doubled.

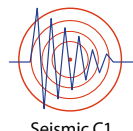
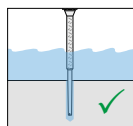

INSTALLATION:

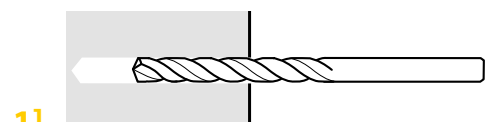

- 1] Drill a hole with correct diameter and depth

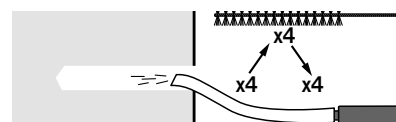

- 2] Clean the drilled hole thoroughly - follow above illustration

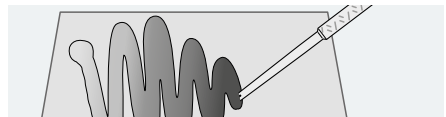

- 3] Eject approximately 10-15 cm mortar in order to ensure correct mixing ratio for injection

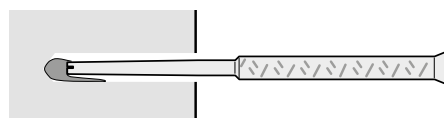

- 4] Insert the mixer into the drilled hole, and while the mixer is slowly retracted inject the correct volume of styrene free injection mortar

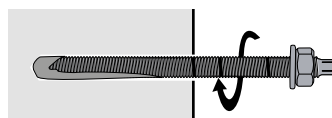

- 5] Insert the threaded rod or socket in a slowly rotating motion, complying with specified embedment depth. For optimal filling of the hole excess mortar should flow out. Observe temperature dependent curing time - see cartridge or matrix on the following page
 OBS: Use always oil free threaded rod!



- 6] After ended curing time the fixing can be loaded - installation is finished

Expandet ESI Xtreme Pro Injection Mortar



EXPANDET ESI XTREME PRO STYRENE FREE INJECTION MORTAR for concrete

TYPE DIMENSION	EXPANDET ARTICLE NO.	PCS. PER CARTON	EAN 13 PER CARTRIDGE
280 ml incl. mixer nozzle	800028	12	5708620103778
350 ml incl. mixer nozzle	800350	12	5708620103792

Professional Injection Gun (H245) is recommended for ESI Xtreme Pro

Design load capacities in non-cracked concrete C20/25								
Dimension of threaded rod (mm)	M8	M10	M12	M16	M20	M24	M27	M30
Effective anchorage depth, h_{ef} (mm)	80	90	110	125	170	210	240	270
Drill hole diameter (mm)	10	12	14	18	22	26	30	35
Minimum thickness of submaterial, h_{min} (mm)	110	120	140	161	218	266	304	340
Tension load, Design resistance N_{Rd} kN*								
4.6 steel	7,5	11,5	17,0	31,5	49,0	70,5	92,0	112,0
5.8 steel	13,4	18,9	27,6	39,2	62,2	85,4	104,3	124,5
8.8 steel	13,4	18,9	27,6	39,2	62,2	85,4	104,3	124,5
A4-70 Stainless Steel	13,4	18,9	27,6	39,2	62,2	85,4	104,3	124,5
A4-80 Stainless Steel	13,4	18,9	27,6	39,2	62,2	85,4	104,3	124,5
HCR steel	13,4	18,9	27,6	39,2	62,2	85,4	104,3	124,5
Shear load, Design resistance V_{Rd} kN*								
4.6 steel	4,2	7,2	10,2	18,6	29,3	42,5	55,1	67,1
5.8 steel	7,2	12,0	16,8	31,2	48,8	70,4	92,0	112,0
8.8 steel	12,0	18,4	27,2	50,4	78,4	112,8	147,2	179,2
A4-70 Stainless Steel	8,3	12,8	19,2	35,3	55,1	79,5	103,2	125,6
A4-80 Stainless Steel	11,3	17,3	25,6	47,4	73,7	106,0	138,3	168,4
HCR Steel	10,4	16,0	24,0	44,0	68,8	99,2	128,8	156,8

* Design resistance is valid for a single anchor in dry/wet non-cracked concrete C20/25 not influenced by edge distance and/or spacing. $\Psi_{re,N} = 1$ (Normal reinforcement according to TR029 5.2.2.3 - 5.2i & 5.2.2.4 - 5.3d).

Design load capacities in cracked concrete C20/25								
Dimension of threaded rod (mm)	M8	M10	M12	M16	M20	M24	M27	M30
Effective anchorage depth, h_{ef} (mm)	80	90	110	125	170	210	240	270
Drill hole diameter (mm)	10	12	14	18	24	28	32	35
Minimum thickness of submaterial, h_{min} (mm)	110	120	140	161	218	266	304	340
Tension load, Design resistance N_{Rd} kN*								
4.6 steel	5,4	7,9	12,7	19,2	32,6	48,4	73,5	88,7
5.8 steel	5,4	7,9	12,7	19,2	32,6	48,4	73,5	88,7
8.8 steel	5,4	7,9	12,7	19,2	32,6	48,4	73,5	88,7
A4-70 Stainless Steel	5,4	7,9	12,7	19,2	32,6	48,4	73,5	88,7
A4-80 Stainless Steel	5,4	7,9	12,7	19,2	32,6	48,4	73,5	88,7
HCR Steel	5,4	7,9	12,7	19,2	32,6	48,4	73,5	88,7
Shear load - Recommended Design resistance V_{Rd} kN*								
4.6 steel	4,2	7,2	10,2	18,6	29,3	42,5	55,1	67,1
5.8 steel	7,2	12,0	16,8	31,2	48,8	70,4	92,0	112,0
8.8 steel	9,7	18,4	27,0	46,1	78,3	112,8	147,2	179,2
A4-70 Stainless Steel	8,3	12,8	19,2	35,3	55,1	79,5	103,2	125,6
A4-80 Stainless Steel	9,7	17,3	24,1	46,1	73,7	106,0	138,4	168,4
HCR Steel	9,7	16,0	24,0	44,0	68,8	99,2	128,8	156,8

* Design resistance is valid for a single anchor in dry/wet cracked concrete C20/25 not influenced by edge distance and/or spacing. $\Psi_{re,N} = 1$ (Normal reinforcement according to TR029 5.2.2.3 - 5.2i & 5.2.2.4 - 5.3d).

Post installed rebar with ESI Xtreme Pro. Design acc. to EN 1992-1-1 (EC2).

ESI Xtreme Pro is CE marked according to EOTA TR023 for rebar (ø8-ø32) and allow for post installing of rebar using ESI Xtreme Pro designed acc. to Eurocode 1992-1-1. Concerning requirements for concretecover, edge distance, spacings and minimum anchorage lengths requirements in EC2 and must be considered. Possible deviations from EC2 described in national annexes are not considered below.

Desing anchorage lengths for straight rebar ($f_y, k = 500 \text{ N/mm}^2$) post installed with ESI Xtreme Pro in concrete C25/30 acc. to EN 1992-1-1 for "good" bond conditions.

Rebar diameter d_s (mm)	Drill diameter d_{cut} (mm)	Cross section A_s (mm ²)	Used Design steel capacity (yield) (kN)	Design anchorage Lengths for design to yield	
				$\alpha_2 = 1,0$	Consumption $\alpha_2 = 1,0$
				(mm)	(ml)
8	12	50,3	21,9	378	29
10	14	78,5	34,1	473	43
12	16	113,1	49,2	567	60
14	18	153,9	66,9	662	80
16	20	201,1	87,4	756	103
20	25	314,2	136,6	945	200
22	28	380,1	165,3	1040	294
24	32	452,4	196,7	1134	479
25	32	490,9	213,4	1181	444

1) $\alpha_1 = \alpha_3 = \alpha_4 = \alpha_5 = \alpha_6 = 1,0$, $\gamma_{m,s} = 1,15$ og $\gamma_{m,c} = 1,5$ acc. to EN 1992-1-1.

* Allowed Drilling Method: Hammer or Compressed air drilling.

INSTALLATION:

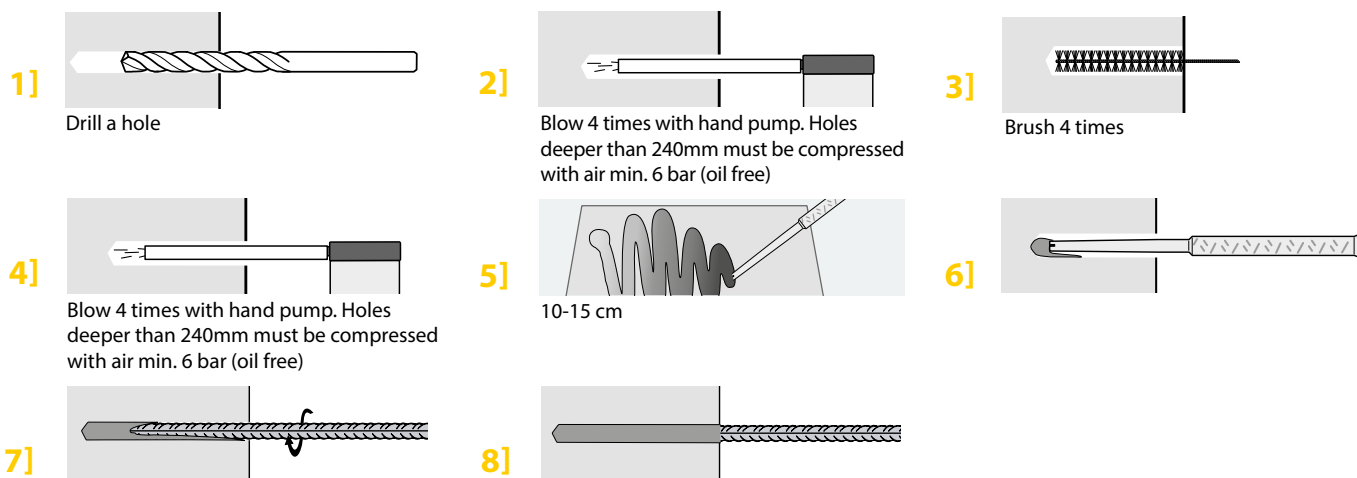

Minimum concrete cover min c of the bonded-in rebar depending on drilling method

Drilling method	Without drilling aid
Hammer drilling	$40 \text{ mm} + 0,06 l_v \geq 2 d_s$
Compressed air drilling	$60 \text{ mm} + 0,08 l_v$

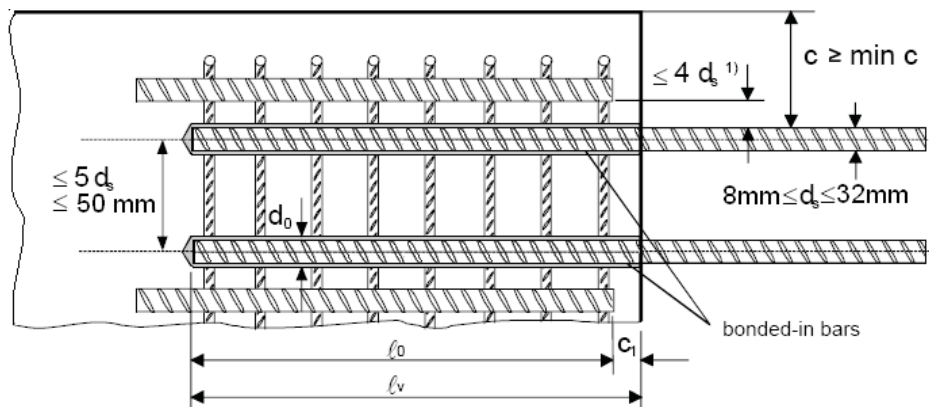

Expandet Injection Mortars ESI Xtreme Pro & EVL Xtreme Pro for fixing of rebar in concrete C20/25 calculated as an anchor in accordance with ETAG 001, TR029.

Below given design loads do not consider reduction due to edge distances or spacing. The rebar is designed as an anchor and thus do not consider requirements given in EC2 for rebar connections.

In case of the design of post installed rebar acc. to EC2 please see page 84 – for details also see Expandet technical data-sheet (ETA acc. EOTA TR023 using ESI Xtreme Pro).

Design load tension capacities								
Rebar as an anchor with ESI Xtreme Pro in concrete C20/25.								
h ₁	h _{nom}	Rebar diameter (mm)						
		Ø8	Ø10	Ø12	Ø16	Ø20	Ø25	Ø32
		Drill diameter (mm) hammerdrill or compressed air drill						
Depth of drill hole mm	Embedment depth mm	12	14	16	20	25	32	40
100	100	14,0	20,9	25,1	28,0	28,0	28,0	
120	120	16,8	25,1	30,2	36,9	36,9	36,9	
140	140	19,5	29,3	35,2	46,5	46,5	46,5	46,5
160	160	20,0	30,7	40,2	53,6	56,8	56,8	56,8
180	180			44,3	52,7	67,8	67,8	67,8
200	200					79,4	79,4	79,4
220	220					91,5	91,5	91,5
240	240					100,5	104,3	104,3
256	256					107,2	114,9	114,9
265	265					111,0	121,0	121,0
280	280					117,3	131,4	131,4
310	310					123,6	147,2	147,2
320	320						151,9	151,9
400	400						189,9	189,9
450	450						192,9	213,6
480	480							277,9
640	640							303,8

Consumption per hole (ml)								
h ₁	h _{nom}	Rebar diameter (mm)						
		Ø8	Ø10	Ø12	Ø16	Ø20	Ø25	Ø32
		Drill diameter (mm) hammerdrill or compressed air drill						
Depth of drill hole mm	Embedment depth mm	12	14	16	20	25	32	40
100	100	9,1	10,8	12,6	16,3	24,8	43,6	60,5
120	120	10,9	13,0	15,1	19,6	29,8	52,3	72,6
140	140	12,7	15,2	17,6	22,9	34,8	61,0	84,7
160	160	14,5	17,3	20,1	26,1	39,7	69,8	96,8
180	180			22,7	29,4	44,7	78,5	109,0
200	200					49,7	87,2	121,1
220	220					54,6	95,9	133,2
240	240					59,6	104,6	145,3
265	265					65,8	115,5	160,4
280	280					69,5	122,1	169,5
310	310					77,0	135,2	187,6
320	320						139,5	193,7
400	400						174,4	242,1
450	450						196,2	272,4
480	480							290,5
640	640							387,4

- 1) Design resistance for tension is valid for a single anchor in dry/wet non-concrete C20/25 not influenced by edge distance and/or spacing: $\geq 1,5 \times h_{nom}$ and $\geq 3 \times h_{nom}$.

INSTALLATION:

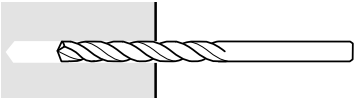
- 

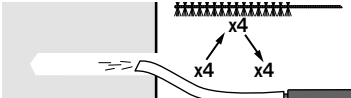
1] Drill a hole in correct diameter and depth. Use either hammer drill or compressed air drilling
- 

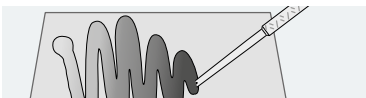
2] Blow 4 times with hand pump. Holes deeper than 240mm must be compressed with air min. 6 bar (oil free)
- 

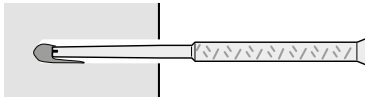
3] Eject approximately 10-15 cm mortar in order to ensure correct mixing ratio for injection
- 

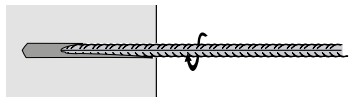
4] Insert the mixer into the drilled hole, and while the mixer is slowly retracted inject the correct volume of styrene free injection mortar
- 

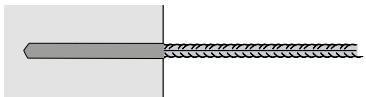
5] Insert reinforcement bar in a slowly rotating motion. For optimal filling of the hole excess mortar should flow out. Observe temperature dependent curing time
- 

6] Installation is finished

Expandet ESI Xtreme Pro Injection Mortar and EVL Xtreme Pro Winter Injection Mortar in masonry type solid and hollow bricks



Solid Brick, Aerated Concrete, Lightweight Aggregate Concrete (LAC) and Solid Sand-Lime Brick/Block.

INSTALLATION:

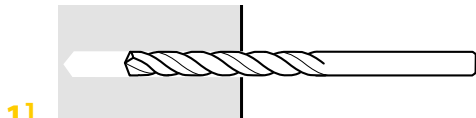

1] Drill a hole with correct diameter and depth

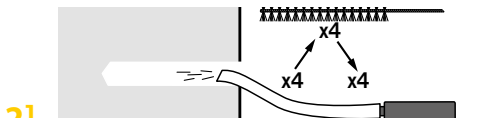

2] Clean the drilled hole thoroughly - follow above illustration

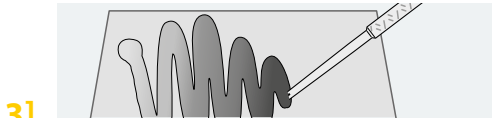

3] Eject approximately 10-15 cm mortar in order to ensure correct mixing ratio for injection

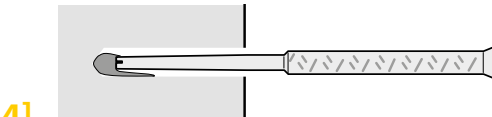

4] Insert the mixer into the drilled hole, and while the mixer is slowly retracted inject the correct volume of styrene free injection mortar

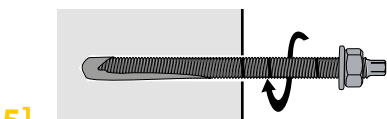

5] Insert the threaded rod or socket in a slowly rotating motion. for optimal filling of the hole excess mortar should flow out. Observe temperature depending on curing time. OBS: Use always oil free threaded rods!



6] After ended curing time the fixing can be loaded and the installation is finished



In hollow materials with sleeve.

INSTALLATION:

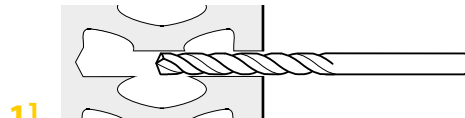

1] Drill a hole with correct diameter and depth

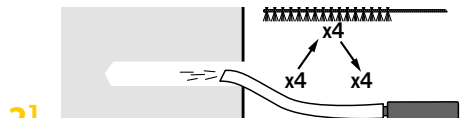

2] Clean the drilled hole thoroughly

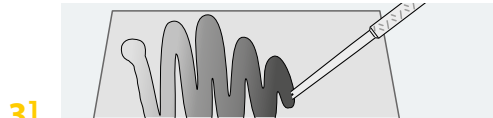

3] Eject approximately 10-15 cm mortar in order to ensure correct mixing ratio for injection

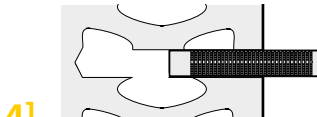

4] Insert sleeve flush with wall

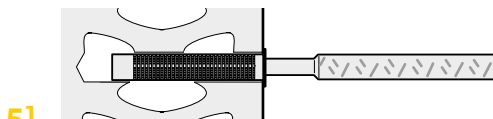

5] Inject mortar from bottom of drilled hole - fill the sleeve completely

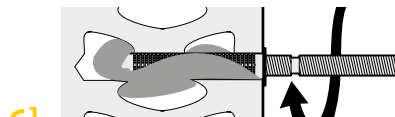

6] Insert the threaded rod or socket in a slowly rotating motion. for optimal filling of the hole excess mortar should flow out. Observe temperature depending on curing time. OBS: Use always oil free threaded rods!



7] After ended curing time the fixing can be loaded and the installation is finished

Installation specifics & Design loads for ESI & EVL Xtreme Pro in different masonry types according ETA at ambient temperatures (24/40)



ESI & EVL Xtreme Pro in Solid Clay Brick (Mz-DF) using hammer or rotary drilling¹⁾

THREADED ROD DIAMETER ³⁾ (MM)	SLEEVE (MM)	DRILL DIAMETER (MM)	DRILL/ EMBEDMENT DEPTH IN BRICK (MM)	BRICK SIZE (LENGTH X WIDTH X HEIGHT) (MM)	MIN. COMPRESSIVE STRENGTH (N/MM ²)	DESIGN LOAD, TENSION ²⁾ (kN)	DESIGN LOAD, SHEAR (kN)
M8	-	10	80	240 x 115 x 55	20	1,80 (2,65)	2,00 (2,94)
M10	-	12	90			2,20 (3,24)	2,00 (2,94)
M12	-	14	100			2,40 (3,53)	2,00 (2,94)
M16	-	18	100			2,40 (3,53)	3,20 (4,71)

¹⁾ Basic load capacities for the brick without edge distance and/or spacing. For details and other configurations see ETA

²⁾ Values in brackets () are with γ_m 1,7 according to Danish National Annex

³⁾ Threaded rod: Zinc plated or Hot dipped galvanised minimum: \geq 5.6 steel. Stainless steel A4: \geq class 70

ESI & EVL Xtreme Pro in Solid Calcium silica Brick KS-NF using hammer or rotary drilling¹⁾

THREADED ROD DIAMETER ³⁾ (MM)	SLEEVE (MM)	DRILL DIAMETER (MM)	DRILL/ EMBEDMENT DEPTH IN BRICK (MM)	BRICK SIZE (LENGTH X WIDTH X HEIGHT) (MM)	MIN. COMPRESSIVE STRENGTH (N/MM ²)	DESIGN LOAD, TENSION ²⁾ (kN)	DESIGN LOAD, SHEAR (kN)
M8	-	10	80	240 x 115 x 71	20	2,40 (3,53)	1,60 (2,35)
M10	-	12	90			2,40 (3,53)	1,80 (2,65)
M12	-	14	100			2,40 (3,53)	1,60 (2,35)
M16	-	18	100			2,00 (2,94)	1,60 (2,35)

¹⁾ Basic load capacities for the brick without edge distance and/or spacing. For details and other configurations see ETA

²⁾ Values in brackets () are with γ_m 1,7 according to Danish National Annex

³⁾ Threaded rod: Zinc plated or Hot dipped galvanised minimum: \geq 5.6 steel. Stainless steel A4: \geq class 70

ESI & EVL Xtreme Pro in Solid light weight concrete (Leca) using rotary drilling only¹⁾

THREADED ROD DIAMETER ³⁾ (MM)	SLEEVE (MM)	DRILL DIAMETER (MM)	DRILL/ EMBEDMENT DEPTH IN BRICK (MM)	BRICK SIZE (LENGTH X WIDTH X HEIGHT) (MM)	MIN. COMPRESSIVE STRENGTH (N/MM ²)	DESIGN LOAD, TENSION ²⁾ (kN)	DESIGN LOAD, SHEAR (kN)
M8	-	10	80	300 x 123 x 248	2	1,20 (1,76)	1,20 (1,76)
M10	-	12	90			1,40 (2,06)	1,40 (2,06)
M12	-	14	100			1,20 (1,76)	1,40 (2,06)
M16	-	18	100			1,20 (1,76)	1,40 (2,06)

¹⁾ Basic load capacities for the brick without edge distance and/or spacing. For details and other configurations see ETA

²⁾ Values in brackets () are with γ_m 1,7 according to Danish National Annex

³⁾ Threaded rod: Zinc plated or Hot dipped galvanised minimum: \geq 5.6 steel. Stainless steel A4: \geq class 70

ESI & EVL Xtreme Pro in Clay Hollow Brick (Doppio Uni) using rotary drilling¹⁾

THREADED ROD DIAMETER ³⁾ (MM)	SLEEVE (MM)	DRILL DIAMETER (MM)	DRILL/ EMBEDMENT DEPTH IN BRICK (MM)	BRICK SIZE (LENGTH X WIDTH X HEIGHT) (MM)	MIN. COMPRESSIVE STRENGTH (N/MM ²)	DESIGN LOAD, TENSION ²⁾ (kN)	DESIGN LOAD, SHEAR (kN)
M8	16 x 85	16	90	250 x 120 x 120	16	0,30 (0,44)	0,60 (0,88)
M10	16 x 85	16	90			0,30 (0,44)	0,60 (0,88)
M12	20 x 85	20	90			0,30 (0,44)	0,60 (0,88)
M16	20 x 85	20	90			0,30 (0,44)	0,60 (0,88)

¹⁾ Basic load capacities for the brick without edge distance and/or spacing. For details and other configurations see ETA

²⁾ Values in brackets () are with γ_m 1,7 according to Danish National Annex

³⁾ Threaded rod: Zinc plated or Hot dipped galvanised minimum: \geq 5.6 steel. Stainless steel A4: \geq class 70

Installation specifics & Design loads for ESI & EVL Xtreme Pro in different masonry types according ETA at ambient temperatures (24/40)



BRICK & CONCRETE

ESI & EVL Xtreme Pro in Clay hollow brick Calibric R+ using rotary drilling only¹⁾

THREADED ROD DIAMETER ³⁾ (MM)	SLEEVE (MM)	DRILL DIAMETER (MM)	DRILL/ EMBEDMENT DEPTH IN BRICK (MM)	BRICK SIZE (LENGTH X WIDTH X HEIGHT) (MM)	MIN. COMPRESSIVE STRENGTH (N/MM ²)	DESIGN LOAD, TENSION ²⁾ (kN)	DESIGN LOAD, SHEAR (kN)
M8	16 x 85	16	90	500 x 200 x 314	12	0,48 (0,71)	2,20 (3,24)
M8	16 x 130	16	135			0,60 (0,88)	2,20 (3,24)
M10	16 x 85	16	90			0,48 (0,71)	2,20 (3,24)
M10	16 x 130	16	135			0,60 (0,88)	2,20 (3,24)
M12	20 x 85	20	90			0,48 (0,71)	3,40 (5,00)
M16	20 x 85	20	90			0,48 (0,71)	3,40 (5,00)

¹⁾ Basic load capacities for the brick without edge distance and/or spacing. For details and other configurations see ETA

²⁾ Values in brackets () are with γ_m 1,7 according to Danish National Annex

³⁾ Threaded rod: Zinc plated or Hot dipped galvanised minimum: ≥ 5.6 steel. Stainless steel A4: ≥ class 70

ESI & EVL Xtreme Pro in Clay hollow brick BGV Thermo using rotary drilling only¹⁾

THREADED ROD DIAMETER ³⁾ (MM)	SLEEVE (MM)	DRILL DIAMETER (MM)	DRILL/ EMBEDMENT DEPTH IN BRICK (MM)	BRICK SIZE (LENGTH X WIDTH X HEIGHT) (MM)	MIN. COMPRESSIVE STRENGTH (N/MM ²)	DESIGN LOAD, TENSION ²⁾ (kN)	DESIGN LOAD, SHEAR (kN)
M8	16 x 85	16	90	500 x 200 x 314	10	0,36 (0,53)	1,40 (2,06)
M8	16 x 130	16	135			0,80 (1,18)	1,60 (2,35)
M10	16 x 85	16	90			0,36 (0,53)	1,40 (2,06)
M10	16 x 130	16	135			0,80 (1,18)	1,60 (2,35)
M12	20 x 85	20	90			0,36 (0,53)	1,60 (2,35)
M16	20 x 85	20	90			0,36 (0,53)	1,60 (2,35)

¹⁾ Basic load capacities for the brick without edge distance and/or spacing. For details and other configurations see ETA

²⁾ Values in brackets () are with γ_m 1,7 according to Danish National Annex

³⁾ Threaded rod: Zinc plated or Hot dipped galvanised minimum: ≥ 5.6 steel. Stainless steel A4: ≥ class 70

ESI & EVL Xtreme Pro in Hollow Light weight concrete Bloc B40 using rotary drilling only¹⁾

THREADED ROD DIAMETER ³⁾ (MM)	SLEEVE (MM)	DRILL DIAMETER (MM)	DRILL/ EMBEDMENT DEPTH IN BRICK (MM)	BRICK SIZE (LENGTH X WIDTH X HEIGHT) (MM)	MIN. COMPRESSIVE STRENGTH (N/MM ²)	DESIGN LOAD, TENSION ²⁾ (kN)	DESIGN LOAD, SHEAR (kN)
M8	16 x 85	16	90	494 x 200 x 190	4	0,48 (0,71)	1,20 (1,76)
M8	16 x 130	16	135			0,48 (0,71)	1,20 (1,76)
M10	16 x 85	16	90			0,48 (0,71)	1,20 (1,76)
M10	16 x 130	16	135			0,48 (0,71)	1,20 (1,76)
M12	20 x 85	20	90			0,48 (0,71)	1,20 (1,76)
M16	20 x 85	20	90			0,48 (0,71)	1,20 (1,76)

¹⁾ Basic load capacities for the brick without edge distance and/or spacing. For details and other configurations see ETA

²⁾ Values in brackets () are with γ_m 1,7 according to Danish National Annex

³⁾ Threaded rod: Zinc plated or Hot dipped galvanised minimum: ≥ 5.6 steel. Stainless steel A4: ≥ class 70

ESI & EVL Xtreme Pro in Hollow Calcium silicate brick KS L-3DF using rotary drilling only¹⁾

THREADED ROD DIAMETER ³⁾ (MM)	SLEEVE (MM)	DRILL DIAMETER (MM)	DRILL/ EMBEDMENT DEPTH IN BRICK (MM)	BRICK SIZE (LENGTH X WIDTH X HEIGHT) (MM)	MIN. COMPRESSIVE STRENGTH (N/MM ²)	DESIGN LOAD, TENSION ²⁾ (kN)	DESIGN LOAD, SHEAR (kN)
M8	16 x 85	16	90	240 x 175 x 113	14	1,00 (1,47)	2,40 (3,53)
M8	16 x 130	16	135			1,00 (1,47)	2,40 (3,53)
M10	16 x 85	16	90			1,00 (1,47)	2,40 (3,53)
M10	16 x 130	16	135			1,00 (1,47)	2,40 (3,53)
M12	20 x 85	20	90			2,60 (3,82)	2,40 (3,53)
M16	20 x 85	20	90			2,60 (3,82)	2,40 (3,53)

¹⁾ Basic load capacities for the brick without edge distance and/or spacing. For details and other configurations see ETA

²⁾ Values in brackets () are with γ_m 1,7 according to Danish National Annex

³⁾ Threaded rod: Zinc plated or Hot dipped galvanised minimum: ≥ 5.6 steel. Stainless steel A4: ≥ class 70