

THROUGHBOLT - BZ

Installation:

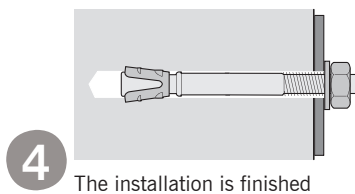

For fixing of heavy objects like steel- and wood structures, base plates and brackets in cracked and non-cracked concrete

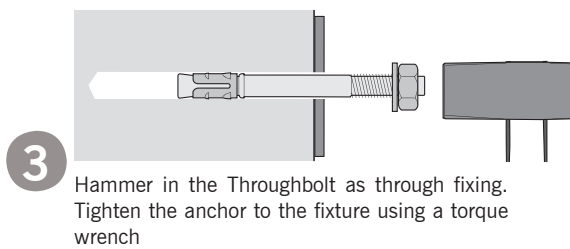
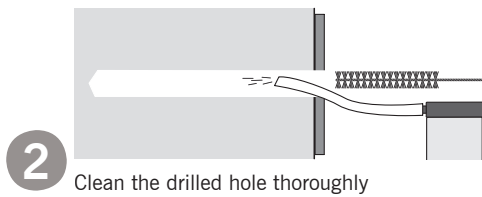
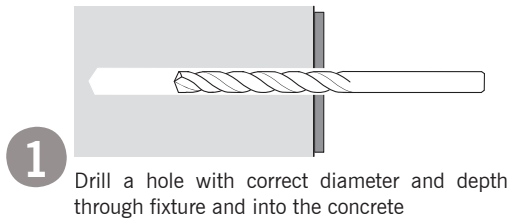
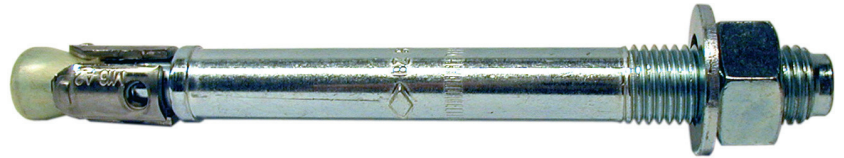

Materials:

Throughbolt BZ is zinc plated min. 5 µm in accordance with EN ISO 4042.

- Bolt: Cold formed steel with plastic-coated cone
- Expansion sleeve: Stainless steel in accordance with EN 10088
- Nut: 8.8 steel in accordance with EN 20 898-2
- Washer: Steel in accordance with EN ISO 7089

Throughbolt BZ-A4 is supplied in Stainless steel (A4).

- Bolt: Stainless steel in accordance with EN 10088
- Expansion sleeve: Stainless steel in accordance with EN 10088
- Nut: Stainless steel in accordance with EN 10088
- Washer: Stainless steel in accordance with EN 10088 and EN ISO 7089

Advantages:

- High load capacities.
- Supplied as an assembled unit.
- Marking of setting depth.
- Letter marked head – easy inspection.
- Approved in cracked concrete.
- Fire approved.
- Can be supplied in stainless steel HCR (High Corrosion Resistance).
- Anchorage can be designed in Expandet Calculation Software.



Approvals:

Throughbolt BZ and BZ-A4 are CE-marked and have European Technical Approval (ETA) in Option 1: Zinc plated (ETA 03/0017), Stainless steel A4 (ETA-99/0010).

Throughbolt BZ and BZ A4 are fire tested.

Anchors in stainless HCR are also fire tested for use in tunnels. VdS approved.



EXPANDET SCREW ANCHORS A/S
Svendebuen 2-6
3230 Græsted
Danmark

Telephone: +45 70 22 79 79
Telefax: +45 70 22 79 89

Version 09.001

www.expandet.dk
expandet@expandet.dk

Grafik: Vedkom / Expandet
©Expandet Screw Anchors A/S, 2006
All rights reserved

THROUGHBOLT - BZ

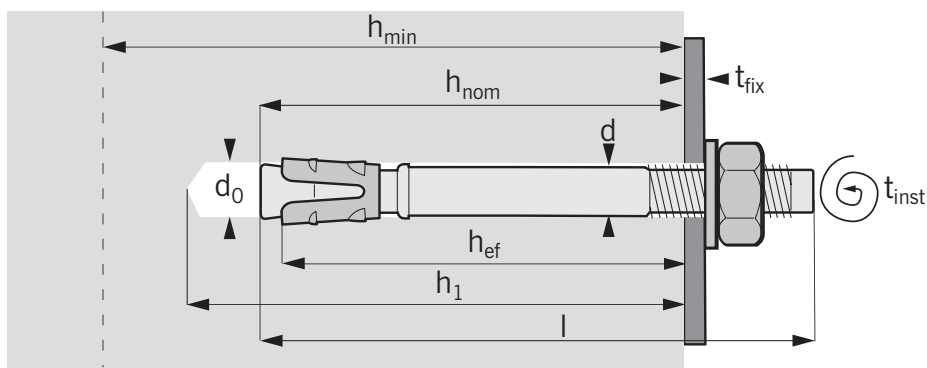

Throughbolt BZ, zinc plated

Type		Dimensions			Fixing								Load Capacities			
		d	L	t _{fix}	d ₀	h ₁	h _{nom}	h _{ef}	T _{inst}	h _{min}	S _{min}	C _{min}	Non-cracked concrete N _{Rd}	Cracked concrete V _{Rd}	Cracked concrete N _{Rd}	Cracked concrete V _{Rd}
Throughbolt BZ	Letter mark	Bolt diameter mm	Anchor length mm	Thickness of fixture (Max.) mm	Drill hole dia. mm	Depth of drilled hole (min) mm	Anchor embedment depth mm	Effective anchorage depth mm	Required setting torque Nm	Thickness of concrete member, min. mm	Minimum allowable spacing mm	Minimum allowable edge distance mm	Design resistance tension kN [♦]	Design resistance shear kN [◇]	Design resistance tension kN [♦]	Design resistance shear kN [◇]
8x 75/ 10	C	M 8	75	10	8	60	52	46	15	100	40	40	6,0	12,0	3,3	12,0
8x 95/ 30	E	M 8	95	30	8	60	52	46	15	100	40	40	6,0	12,0	3,3	12,0
8x115/ 50	G	M 8	115	50	8	60	52	46	15	100	40	40	6,0	12,0	3,3	12,0
10x 90/ 10	E	M10	90	10	10	75	67	60	25	120	45	50 (45)	8,0	17,6	6,0	17,6
10x100/ 20	E	M10	100	20	10	75	67	60	25	120	45	50 (45)	8,0	17,6	6,0	17,6
10x110/ 30	F	M10	110	30	10	75	67	60	25	120	45	50 (45)	8,0	17,6	6,0	17,6
10x130/ 50	H	M10	130	50	10	75	67	60	25	120	45	50 (45)	8,0	17,6	6,0	17,6
12x115/ 20	G	M12	115	20	12	90	80	65	45	130	60	75 (60)	10,7	26,4	8,0	25,1
12x145/ 50	I	M12	145	50	12	90	80	65	45	130	60	75 (60)	10,7	26,4	8,0	25,1
12x180/ 85	L	M12	180	85	12	90	80	65	45	130	60	75 (60)	10,7	26,4	8,0	25,1
12x220/125	O	M12	220	125	12	90	80	65	45	130	60	75 (60)	10,7	26,4	8,0	25,1
12x240/145	P	M12	240	145	12	90	80	65	45	130	60	75 (60)	10,7	26,4	8,0	25,1
12x255/160	R	M12	255	160	12	90	80	65	45	130	60	75 (60)	10,7	26,4	8,0	25,1
16x145/ 25	I	M16	145	25	16	110	100	85	90	170	65 (60)	80 (60)	20,0	48,0	16,6	37,6
16x170/ 50	K	M16	170	50	16	110	100	85	90	170	65 (60)	80 (60)	20,0	48,0	16,6	37,6
16x220/100	O	M16	220	100	16	110	100	85	90	170	65 (60)	80 (60)	20,0	48,0	16,6	37,6
16x260/140	R	M16	260	140	16	110	100	85	90	170	65 (60)	80 (60)	20,0	48,0	16,6	37,6
16x300/180	S	M16	300	180	16	110	100	85	90	170	65 (60)	80 (60)	20,0	48,0	16,6	37,6
20x165/ 30	K	M20	165	30	20	125	114	100	160	200	90 (95)	130 (95)	26,6	51,9	24,0	48,0
20x195/ 60	M	M20	195	60	20	125	114	100	160	200	90 (95)	130 (95)	26,6	51,9	24,0	48,0
20x265/130	R	M20	265	130	20	125	114	100	160	200	90 (95)	130 (95)	26,6	51,9	24,0	48,0
24x190/ 30	L	M24	190	30	24	145	133	115	200	230	100	100	41,4	82,8	29,6	59,2
24x220/ 60	O	M24	220	60	24	145	133	115	200	230	100	100	41,4	82,8	29,6	59,2

Loads in () are only valid for fixing in cracked concrete together with corresponding design load capacity.

- ♦ Design resistance for tension is valid for a single anchor in concrete C20/25 not influenced by edge distance and/or spacing: $C \geq 1,5 h_{ef}$ and $S \geq 3 h_{ef}$, $\Psi_{re,N} = 1$ (Normal reinforcement according to ETAG 001, Annex C - 5.2.2.4).
- ◇ Design resistance for shear is valid for a single anchor in concrete $\geq C20/25$ not influenced by edge distance and/or spacing: $C \geq 10 h_{ef}$ and $S \geq 3 h_{ef}$.

Partial safety factor for material (γ_m) is included in accordance with product ETA. Partial safety factor for action (γ_t) has to be applied in accordance with national building code. If no guidance for γ_t exists ETAG 001, Annex C recommends factor 1,35 for permanent action and factor 1,5 for variable action.

Combined resistance shall be verified if both tension and shear actions are applied. See "Principles for Fastening" page 5 (Verification Method 2).

When calculating load capacity for anchor or anchorgroup use Expandet Calculation Software allowing for design with individual edge distance and spacing in accordance with ETAG 001, Annex C, Design Method A. Download Expandet Calculation Software for free at www.expandet.com.

Important: See Expandet's "Principles for fastening" for general information on fastening as well as information on limited liability. (Can be downloaded at www.expandet.com)

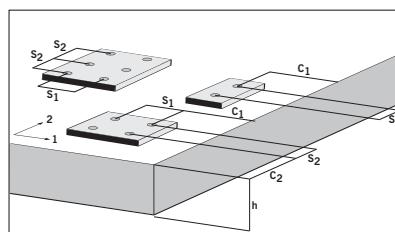

THROUGHBOLT - BZ

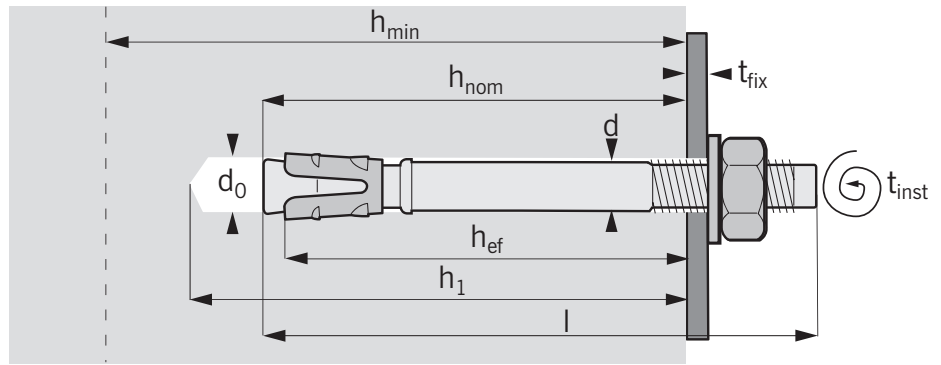

Throughbolt BZ, stainless steel A4

Type		Dimensions			Fixing								Load Capacities			
Throughbolt BZ	Letter mark	d	L	t _{fix}	d ₀	h ₁	h _{nom}	h _{ef}	T _{inst}	h _{min}	S _{min}	C _{min}	Non-cracked concrete		Cracked concrete	
													N _{Rd}	V _{Rd}	N _{Rd}	V _{Rd}
		mm	mm	mm	mm	mm	mm	mm	Nm	mm	mm	mm	Design resistance tension kN♦	Design resistance shear kN°	Design resistance tension kN♦	Design resistance shear kN°
8x 75/ 10	C	M 8	75	10	8	60	52	46	15	100	40	40	6,0	10,4	3,3	10,4
8x 95/ 30	E	M 8	95	30	8	60	52	46	15	100	40	40	6,0	10,4	3,3	10,4
8x115/ 50	G	M 8	115	50	8	60	52	46	15	100	40	40	6,0	10,4	3,3	10,4
10x 90/ 10	E	M10	90	10	10	75	67	60	35	120	50 (45)	60 (55)	8,0	16,0	6,0	16,0
10x 95/ 10	E	M10	95	10	10	75	67	60	35	120	50 (45)	60 (55)	8,0	16,0	6,0	16,0
10x110/ 30	F	M10	110	30	10	75	67	60	35	120	50 (45)	60 (55)	8,0	16,0	6,0	16,0
10x130/ 50	H	M10	130	50	10	75	67	60	35	120	50 (45)	60 (55)	8,0	16,0	6,0	16,0
12x115/ 20	G	M12	115	20	12	90	80	65	50	130	60	75 (60)	10,7	24,0	8,0	24,0
12x145/ 50	I	M12	145	50	12	90	80	65	50	130	60	75 (60)	10,7	24,0	8,0	24,0
12x180/ 85	L	M12	180	85	12	90	80	65	50	130	60	75 (60)	10,7	24,0	8,0	24,0
12x220/125	O	M12	220	125	12	90	80	65	50	130	60	75 (60)	10,7	24,0	8,0	24,0
16x140/ 25	I	M16	140	25	16	110	95	85	110	160	65	80 (60)	20,0	44,0	16,6	37,6
16x165/ 50	J	M16	165	50	16	110	95	85	110	160	65	80 (60)	20,0	44,0	16,6	37,6
16x215/100	N	M16	215	100	16	110	95	85	110	160	65	80 (60)	20,0	44,0	16,6	37,6
20x165/ 30	J	M20	165	30	20	125	114	100	160	200	90 (95)	130 (95)	26,6	61,4	24,0	48,0
20x195/ 60	M	M20	195	60	20	125	114	100	160	200	90 (95)	130 (95)	26,6	61,4	24,0	48,0
20x235/100	P	M20	235	100	20	125	114	100	160	200	90 (95)	130 (95)	26,6	61,4	24,0	48,0

Loads in () are only valid for fixing in cracked concrete together with corresponding design load capacity.

- ♦ Design resistance for tension is valid for a single anchor in concrete C20/25 not influenced by edge distance and/or spacing: $C \geq 1,5 h_{ef}$ and $S \geq 3 h_{ef}$. $\Psi_{re,N} = 1$ (Normal reinforcement according to ETAG 001, Annex C - 5.2.2.4).
- ° Design resistance for shear is valid for a single anchor in concrete $\geq C20/25$ not influenced by edge distance and/or spacing: $C \geq 10 h_{ef}$ and $S \geq 3 h_{ef}$.

Partial safety factor for material (γ_m) is included in accordance with product ETA. Partial safety factor for action (γ_f) has to be applied in accordance with national building code. If no guidance for γ_f exists ETAG 001, Annex C recommends factor 1,35 for permanent action and factor 1,5 for variable action.

Combined resistance shall be verified if both tension and shear actions are applied. See "Principles for Fastening" page 5 (Verification Method 2).

When calculating load capacity for anchor or anchorgroup use Expandet Calculation Software allowing for design with individual edge distance and spacing in accordance with ETAG 001, Annex C, Design Method A. Download Expandet Calculation Software for free at www.expandet.com.

Important: See Expandet's "Principles for fastening" for general information on fastening as well as information on limited liability. (Can be downloaded at www.expandet.com)

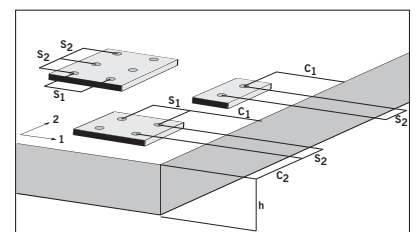

THROUGHBOLT - BZ

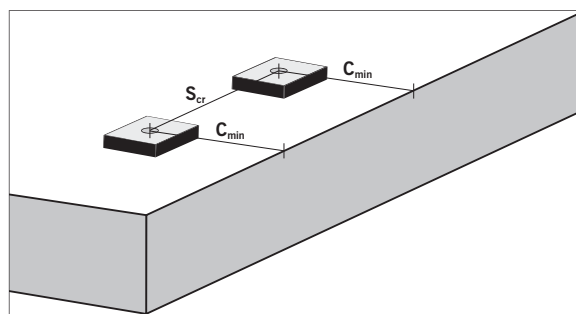

Design shear load capacity for a single anchor at minimum edge distance (C_{min})[♦]

Throughbolt BZ - zinc plated		M8	M10	M12	M16	M20	M24
$V_{Rd,c}$ (cracked concrete)	kN	1,52	2,04	3,38	3,89	8,57	10,05
C_{min} (cracked concrete)	mm	40	45	60	60	95	100
S_{cr} (cracked concrete)	mm	70	90	140	180	285	300
$V_{Rd,c}$ (non-cracked concrete)	kN	2,13	3,36	6,62	8,39	19,21	14,07
C_{min} (non-cracked concrete)	mm	40	50	75	80	130	100
S_{cr} (non-cracked concrete)	mm	80	100	150	150	390	300
Throughbolt BZ - stainless steel A4		M8	M10	M12	M16	M20	-
$V_{Rd,c}$ (cracked concrete)	kN	1,52	2,76	3,38	3,89	8,57	-
C_{min} (cracked concrete)	mm	40	55	60	60	95	-
S_{cr} (cracked concrete)	mm	70	90	140	180	285	-
$V_{Rd,c}$ (non-cracked concrete)	kN	2,13	4,42	6,62	8,39	19,21	-
C_{min} (non-cracked concrete)	mm	40	60	75	80	130	-
S_{cr} (non-cracked concrete)	mm	80	120	150	150	390	-

♦ Design resistance for shear is valid at minimum edge distance in concrete C20/25 providing that characteristic spacing is $\geq S_{cr}$.

Partial safety factor for edge failure (γ_{mc}) is included in accordance with product ETA.

Use Expandet Calculation Software for calculation of load capacity for anchor and anchorage in accordance with ETAG 001, Annex C – Design Method A.

Design shear load capacity for steel failure and resistance against bending (lever arm) for a single anchor[◇]

Throughbolt BZ - zinc plated		M8	M10	M12	M16	M20	M24
$V_{Rd,s}$	kN	12,0	17,6	26,6	48,0	51,8	91,2
M_{Rd}	Nm	18,4	37,6	65,6	167,2	272,9	718,4
Throughbolt BZ - stainless steel A4		M8	M10	M12	M16	M20	M24
$V_{Rd,s}$	kN	10,4	16,0	24,0	44,0	61,4	-
M_{Rd}	Nm	20,8	41,6	43,6	186,4	324,2	-

◇ Design values include partial safety factor for material (γ_{ms}) in accordance with product ETA.